

Application News

Measuring Water/Coolant And Oil Flow In Racing Engines

Industry: Automotive **Service:** Flow Monitoring & Control **Fluid:** Water/Coolant and Engine Oil

Overview

Today's high-performance racing engines operate under extreme stress. The job of oil in these engines involves more than merely providing lubrication for rotating and sliding surfaces; it also acts as a coolant. Engine coolant and water play another important part in maintaining proper engine temperature. Heat from combustion and friction is conducted into the block and heads. It then goes into the engine coolant and is rejected by the radiator.

Situation

A leading manufacturer of racing engines employed a dyno test cell to evaluate the performance of water/coolant and oil under challenging conditions. The test cell subjected internal engine components to high temperature and friction. The test results were used in heat balance studies to help the manufacturer make correct decisions when designing parts and choosing engine coolants/lubricants.

During testing, the engine manufacturer measures water/coolant flow in a range from 15 to 150 Gallons Per Minute (GPM). A pulse output of the flow reading is supplied to the test cell's data acquisition system for engine analysis. Measuring engine oil is a different story. The test cell measures oil flow between 0.6 and 60 GPM. Due to variations in temperature, the oil viscosity tends to shift. This required test cell operators to compensate for temperature changes in order to obtain an accurate flow measurement.

Solution

The engine manufacturer selected Flow Technology, Inc. to supply a turbine flow meter system for its engine test cell. The flow measurement equipment was supplied without access to temperature and viscosity data related to the customer's specific oil curve.

The turbine meter design is ideally suited to test cell applications. It features high accuracy and repeatability, compact size, and fast speed-of-response. For measurements where temperature changes during the test, the Linear Link® Temperature Compensated Interface (TCI) electronics package can be used. The Linear Link® TCI measures temperature, performs real-time correction for viscosity and density changes, and provides a corrected output for both flow and temperature.

System Description

The flow measurement solution for measuring water/coolant consisted of a 1.5-inch FT Series turbine meter paired with an amplifier to provide the pulse output. The meter was equipped with carbide journal bearings for added durability and compatibility with the water solution. For measuring oil, the test cell utilized a 1-inch FT Series turbine meter with an RTD built into the pick-off to sense the temperature of the fluid, as well as the Linear Link® TCI and Link® TCI programming cable. The temperature signal is transmitted to the Link® TCI along with the flow meter frequency.

The turbine meters were calibrated using a "U3" Universal Viscosity Curve at three different viscosities: 3 cSt, 10 cSt and 30 cSt. The Linear Link® TCI was also factory-scaled with this calibration curve. Test cell operators used their PC or laptop with the RS232 port, programming cable, and free Visual Link software download from the Flow Technology web site to create a "custom" calibration curve based on the set-up program. This solution provided a way of measuring flow rate while compensating for viscosity shifts due to temperature changes.

Technical Information

Flow Meter: FT-24AENW-LED-5, CA03-3-C-0000-9

Flow Rate: 15-150 GPM

Fluid: Water/Coolant

Flow Meter: FT-16AEU3-LEAT5, LNT-3-C0-V1-9, 19-62627-102

Flow Rate: 0.6-60 GPM

Fluid: Engine Oil

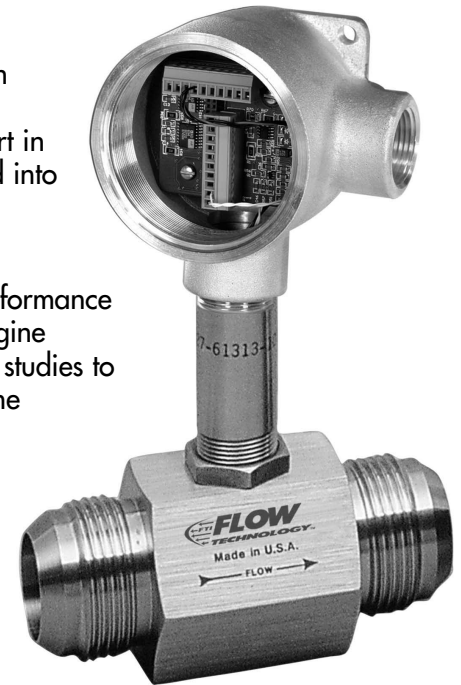

8930 S. Beck Ave., Suite 107 • Tempe, AZ, 85284 USA
Tel: 480.240.3400 • Fax: 480.240.3401 • Toll-free: 800.528.4225

E-mail: ftmarket@ftimeters.com • Web: www.ftimeters.com

©2007 Flow Technology, Inc. DB-68969 Rev. A